

API GATE VALVE

1. USE:

Extraction, transportation and distribution systems in:
water, steam, gas and oil industry.

2. SERVICE CONDITIONS:

- 2.1. Ambient temperature: from -35°C to $+40^{\circ}\text{C}$
(-22°F to $+104^{\circ}\text{F}$)
- 2.2. Service temperature: from -59°C to $+595^{\circ}\text{C}$
(-75°F to $+1100^{\circ}\text{F}$)

3. TECHNICAL CHARACTERISTICS:

- 3.1. Design standard: API 600 and API SPEC. 6D
- 3.2. End-to-end dimensions:
ASME B16.10 for NPS 1" ÷ 36",
manufacturer's standard for NPS 38" ÷ 56"
- 3.3. Connection flanges:
ASME B16.5 for NPS 1" ÷ 24",
MSS SP 44 or ASME B16.47 for NPS 22" ÷ 56"
- 3.4. Weld ends: ASME B16.25 or ASME B31.1
- 3.5. Temperature pressure rating: ASME B16.34
- 3.6. Testing: API 598 or API SPEC. 6D
- 3.7. Operation: manual - handwheel
- gear
electrical - actuator

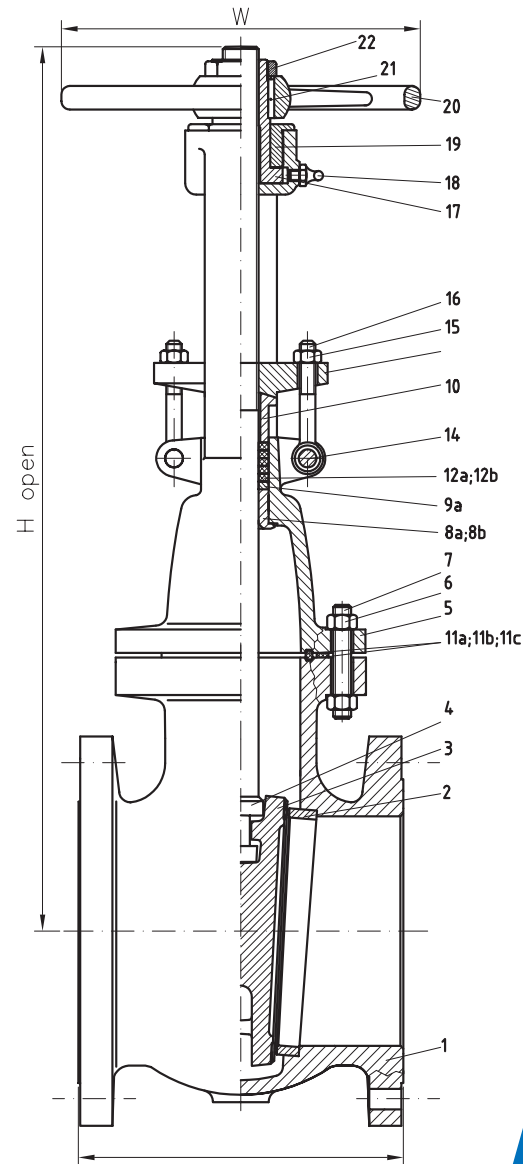

The Science Of Detail

API GATE VALVE

4. MATERIALS

No.	Name of Part	ASTM SPECIFICATION								
		Standard			High Temperature			Low Temperature Service		
		-20°F 800°F -29°C 427°C	-20°F 850°F -29°C 455°C	-20°F 1000°F -29°C 538°C	-20°F 1100°F -29°C 594°C	-20°F 1100°F -29°C 594°C	-50°F 650°F -46°C 345°C	-50°F 700°F -46°C 370°C	-75°F 650°F -59°C 345°C	
1	Body	A216-WCB	A217-WC1	A217-WC6	A217-WC9	A217-C5	A352-LCB	A352-LCC	A352-LC1	
2	Welded Seat Ring	A53-A/A573 gr. 65	A691-CM-70/A204 gr. A	A182-F11 CL. 2	A182-F22 CL. 3	A182-F5a	A672-B65/A515 gr. 65	A672-B65/A516 gr. 65	A691-CM-70/A204 gr. B	
3	Gate	Forged	A182-F6	A182-F6	A182-F316	A182-F316	A182-F316	A182-F304	A182-F304	A182-F304
		Casting	A216-WCB	A217-WC1	A217-WC6	A217-WC9	A217-C5	A352-LCB	A352-LCC	A352-LC1
4	Stem	A182-F6a	A182-F6a	A182-F316	A182-F316	A182-F316	A182-F304	A182-F304	A182-F304	
5	Bonnet	A216-WCB	A217-WC1	A217-WC6	A217-WC9	A217-C5	A352-LCB	A352-LCC	A352-LC1	
6	Bonnet Nuts	A194-2H	A194-2H	A194-2H or A194-4	A194-2H or A194-4	A194-2H or A194-4	A194-4	A194-4	A194-4	
7	Bonnet Studs	A193-B7	A193-B7	A193-2H or A193-B16	A193-2H or A193-B16	A193-2H or A193-B16	A320-L7M	A320-L7M	A320-L7M	
8a	Backseat	Thread	A182-F6a	A182-F6a	A182-F316	A182-F316	A182-F316	A182-F304	A182-F304	A182-F304
8b	Bushing	Welded	A108 gr.1025	A182-F1	A182-F11 CL. 2	A182-F22 CL. 3	A182-F5a	A350-LF2	A350-LF2	A182-F1
9a	Packing Washer	A108 gr.1025	A182-F1	A182-F11 CL. 2	A182-F22 CL. 3	A182-F5a	A350-LF2	A350-LF2	A182-F1	
9b	Lantern	A108 gr.1025	A182-F1	A182-F11 CL. 2	A182-F22 CL. 3	A182-F5a	A350-LF2	A350-LF2	A182-F1	
10	Gland	A108 gr.1025	A182-F1	A182-F11 CL. 2	A182-F22 CL. 3	A182-F5a	A350-LF2	A350-LF2	A182-F1	

No.	Name of Part	
11a	Bonnet Gasket	Plane gasket – graphite with metal filler class 150
11b		Spiral wound gasket – stainless steel with graphite filler
11c		Ring-Joint gasket – carbon steel or stainless steel, as required
12a	Packing	Graphite with metal filler and corrosion inhibitor
12b		Graphite with corrosion inhibitor
13	Gland Flange	A105/A573 gr. 65
14	Gland Lug Bolts	A108 gr. 1035
15	Gland Nuts	A194-2H
16	Gland Bolts	A193-B7
17	Stem Bushing	A439-D2C
18	Lubricant Fitting	Commercial
19	Stem Bushing Locknut	Carbon Steel
20	Handwheel	A216-WCB
21	Handwheel Key	Carbon Steel
22	Handwheel Nuts	Carbon Steel
23	Bearing Cap	A216-WCB
24	Cap Screws	A193-B7
25	Bearings	Commercial
26	Ring	Viton
27	Locknut	Carbon Steel
28	Yoke	A216-WCB
29a;29b	Yoke Bolts	A193-B7
30a;30b	Yoke Nuts	A194-2H
31	Linking Part	A216-WCB
32	Actuator Bushing	Carbon Steel
33	Actuator Bolts	Commercial
34	Actuator Nuts	Commercial
35	Manual Actuator	Commercial
36	Electric Motor Actuator	Commercial

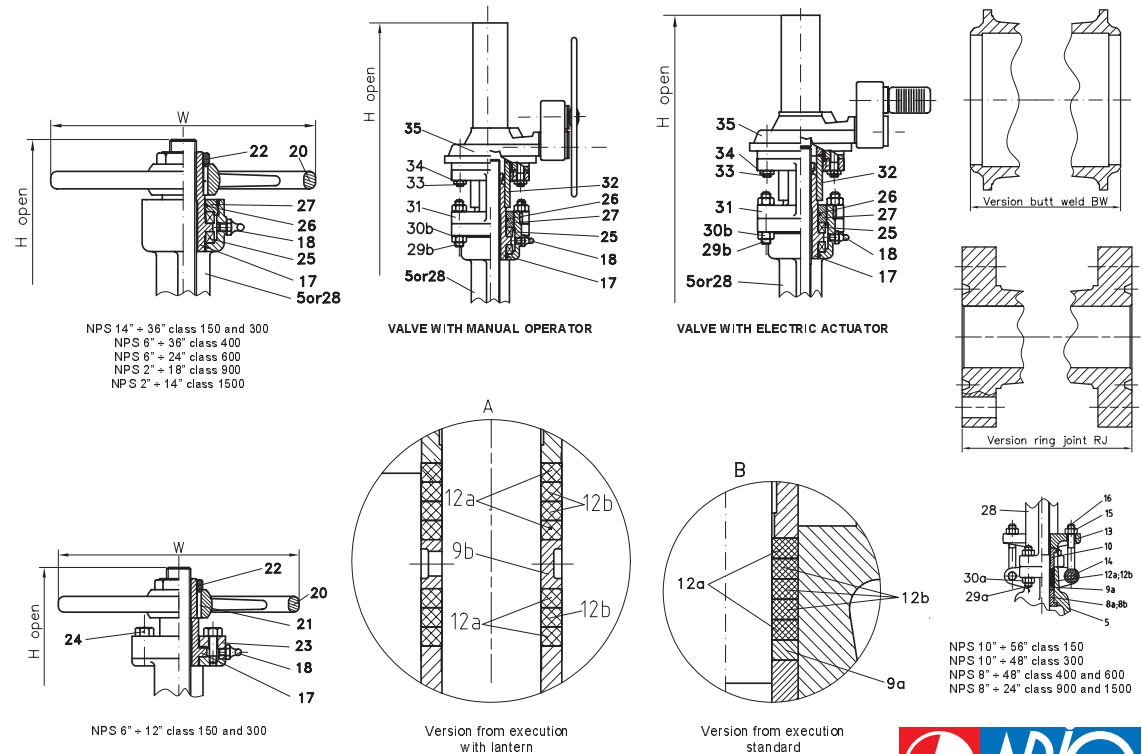

GATE VALVE CLASS 150

Overall dimensions	NPS	inch	1 1/2"	2"	2 1/2"	3"	4"	5"	6"	8"	10"	12"	14"	16"	18"	20"	22"	24"	26"	28"	30"	32"	36"	40"	42"	48"	52"	56"
	DN	mm	40	50	65	80	100	125	150	200	250	300	350	400	450	500	550	600	650	700	750	800	900	1000	1050	1200	1300	1400
	RF	inch	6 1/2"	7"	7 1/2"	8"	9"	10"	10 1/2"	11 1/2"	13"	14"	15"	16"	17"	18"	19"	20"	22"	24"	24"	28"	28"	34"	36"	44"	44 1/2"	45"
		mm	165	178	191	203	229	254	267	292	330	356	381	406	432	457	483	508	559	610	610	711	711	864	914	1118	1130	1134
	RJ	inch	7 1/2"	7 1/2"	8"	8 1/2"	9 1/2"	10 1/2"	11"	12"	13 1/2"	14 1/2"	15 1/2"	16 1/2"	17 1/2"	18 1/2"	19 1/2"	20 1/2"										
		mm	178	191	203	216	241	267	279	305	343	368	394	419	445	470	495	521										
	BW	inch	6 1/2"	8 1/2"	9 1/2"	11 1/8"	12"	15"	15 7/8"	16 1/2"	18"	19 3/4"	22 1/2"	24"	26"	28"	30"	32"	34"	36"	36"	38"	40"	42"	43"	50"	52"	60"
mm		178	216	241	283	305	381	403	419	457	502	572	610	660	711	762	813	864	914	914	965	1016	1067	1092	1270	1321	1524	
H	inch	14 5/8"	14 7/8"	16 1/4"	18 3/8"	22 3/8"	26 7/8"	31 1/4"	39 1/4"	47 1/2"	56"	65"	73 7/8"	81"	92 5/8"	99 1/2"	106 3/8"	114 7/8"	125 1/4"	134 3/8"	135"	153 3/8"	171 1/2"	187"	211"	238"	262 1/2"	
open	mm	365	378	409	467	568	683	794	997	1206	1422	1651	1864	2057	2353	2527	2702	2918	3181	3413	3429	3896	4356	4750	5359	6045	6668	
W	inch	6 1/2"	6 1/2"	6 1/2"	9"	10"	12"	12"	14"	16"	20"	20"	22"	26"	26"	26"	30"	30"	30"	30"	30"	30"	Gear operated					
	mm	178	178	178	228	254	305	305	358	406	508	508	559	660	660	660	762	838	838	838	838	838						
Net weight	RF	lbs.	25	37	57	71	108	157	194	313	459	672	922	1241	1526	2059	2249	2864	3439	5644	5803	7848	9418	10472	11795	16799	27006	31570
		kg	16	17	26	32	49	71	88	142	208	305	418	563	692	934	1020	1299	1560	2560	2632	3560	4272	4750	5350	7620	12250	14320
	BW	lbs.	29	31	44	64	104	143	176	293	399	637	893	1135	1404	1823	2127	2639	3164	5269	5362	7584	8558	98281	11409	16358	26742	30776
		kg	13	14	20	29	47	65	80	133	181	289	405	515	637	827	965	1197	1435	2390	2432	3440	3882	44580	5175	7420	12130	13960

GATE VALVE CLASS 300

Overall dimensions	NPS	inch	1 1/2"	2"	2 1/2"	3"	4"	5"	6"	8"	10"	12"	14"	16"	18"	20"	22"	24"	26"	28"	30"	32"	36"	40"	42"	48"	
	DN	mm	40	50	65	80	100	125	150	200	250	300	350	400	450	500	550	600	650	700	750	800	900	1000	1050	1200	
	RF	inch	7 1/2"	7 1/2"	8 1/2"	11 1/8"	12"	15"	15 7/8"	16 1/2"	18"	19 3/4"	30"	33"	36"	39"	43"	45"	49"	53"	55"	60"	68"	76"	78"	87 1/4"	
	BW	mm	191	216	241	283	305	381	403	419	457	502	762	838	914	991	1092	1143	1245	1346	1397	1524	1727	1930	1981	2215	
	RJ	inch	8"	9 1/8"	10 1/8"	11 3/4"	11 5/8"	15 5/8"	16 1/2"	17 1/8"	18 5/8"	20 3/8"	30 5/8"	33 5/8"	36 5/8"	39 3/4"	43 7/8"	45 7/8"	50"	54"	56"	61 1/8"	69 1/8"				
		mm	203	232	257	298	321	397	419	435	473	518	778	854	930	1010	1114	1165	1270	1372	1422	1553	1756				
	H	inch	15 1/4"	15 3/4"	17"	19 1/2"	24 1/8"	28 3/4"	33 3/8"	41 1/2"	50 1/2"	57 7/8"	66"	74"	84 1/4"	93"	102 3/4"	112 1/4"	115 1/2"	123 1/2"	129 1/4"	136"	151 1/2"	188 5/8"	198 1/8"	217 3/8"	
open	mm	387	400	432	495	613	730	848	1054	1283	1470	1676	1880	2140	2362	2607	2851	2934	3237	3283	3454	3848	4791	5032	5522		
W	inch	6 1/2"	6 1/2"	6 1/2"	9"	10"	12"	14"	16"	20"	20"	22"	26"	26"	30"	30"	33"	33"	39 3/8"	39 3/8"	39 3/8"	39 3/8"	Gear operated				
	mm	178	178	178	228	254	305	358	406	508	508	559	660	660	762	762	838	838	1000	1000	1000	1000					
Net weight	RF	lbs.	44	57	86	112	172	265	335	518	813	1129	1872	2363	4131	4367	5467	6482	7540	8488	9943	11905	15322	18849	25353	31685	
		kg	20	26	39	51	78	120	152	235	369	512	849	1072	1874	1981	2480	2940	3420	3850	4510	5400	6950	8550	11500	14372	
	BW	lbs.	40	46	62	101	150	231	269	439	697	893	1587	2238	3933	4079	5170	5882	7099	8025	9348	11177	14378	17394	23766	29502	
		kg	18	21	28	46	68	105	122	199	316	405	720	1015	1784	1850	2345	2668	3220	3640	4240	5070	6522	7890	10780	13382	

GATE VALVE CLASS 400

Overall dimensions	NPS	inch	1 1/2"	2"	2 1/2"	3"	4"	5"	6"	8"	10"	12"	14"	16"	18"	20"	22"	24"	26"	28"	30"	32"	36"	40"	42"	48"	
	DN	mm	40	50	65	80	100	125	150	200	250	300	350	400	450	500	550	600	650	700	750	800	900	1000	1050	1200	
	RF	inch	9 1/2"	9 1/2"	11 1/2"	13"	14"	18"	19 1/2"	23 1/2"	26 1/2"	30"	32 1/2"	35 1/2"	38 1/2"	41 1/2"	45"	48 1/2"	51 1/2"	55"	60"	65"	74"	79"	81"	90 1/4"	
	BW	mm	241	292	330	356	406	457	495	597	673	762	826	902	978	1054	1143	1232	1308	1397	1524	1651	1880	2007	2057	2292	
	RJ	inch	10"	11 5/8"	13 1/8"	14 1/8"	16 1/8"	18 5/8"	19 5/8"	23 5/8"	26 5/8"	30 1/8"	32 5/8"	35 5/8"	38 5/8"	41 3/4"	45 3/8"	48 7/8"	52"	55 1/2"	60 1/2"	65 5/8"	74 5/8"				
		mm	254	295	333	359	410	473	498	600	676	765	829	905	981	1060	1153	1241	1321	1410	1537	1667	1895				
	H	inch	15 3/4"	16 1/4"	17 1/2"	20"	24 7/8"	29 1/2"	34 7/8"	42 1/2"	51 1/2"	58 7/8"	67 1/2"	75 1/2"	85 3/4"	94 1/2"	104 1/4"	113 3/4"	117 1/2"	125 1/2"	131 3/4"	138"	154 1/2"	191 5/8"	201 1/8"	220 3/8"	
open	mm	400	413	445	508	632	749	886	1079	1308	1495	1714	1918	2178	2400	2648	2889	2985	3188	3346	3505	3924	4867	5108	5597		
W	inch	7"	9"	9"	10"	12"	14"	16"	20"	22"	22"	22"	26"	26"	30"	30"	33"	33"	39 3/8"	39 3/8"	39 3/8"	39 3/8"	Gear operated				
	mm	178	228	228	254	305	358	406	508	559	559	559	660	660	762	762	838	838	1000	1000	1000	1000					
Net weight	RF	lbs.	60	75	123	146	234	364	470	827	1228	1698	2632	3296	5108	6096	8051	9914	11409	12842	14760	16336	19786	27282	33069	47258	
		kg	27	34	56	66	106	165	213	375	557	770	1194	1495	2317	2765	3652	4497	5175	5825	6695	7410	8975	12375	15000	21436	
	BW	lbs.	51	64	106	123	198	320	412	739	1102	1523	2403	3000	4824	5752	7522	9295	10968	12379	14165	15609	18882	25827	31482	45075	
		kg	23	29	48	56	90	145	187	335	500	691	1090	1361	2188	2609	3412	4216	4975	5615	6425	7080	8565	11715	14280	20446	

GATE VALVE CLASS 600

Overall dimensions	NPS	inch	1 1/2"	2"	2 1/2"	3"	4"	5"	6"	8"	10"	12"	14"	16"	18"	20"	22"	24"	26"	28"	30"	32"	36"	40"	42"	48"		
	DN	mm	40	50	65	80	100	125	150	200	250	300	350	400	450	500	550	600	650	700	750	800	900	1000	1050	1200		
	RF;	inch	9 1/2"	11 1/2"	13"	14"	17"	20"	22"	26"	31"	33"	35"	39"	43"	47"	51"	55"	57"	61"	65"	70"	82"	76"	78"	87 1/4"		
	BW	mm	241	292	330	356	432	495	559	660	787	838	889	991	1092	1194	1295	1397	1448	1549	1651	1778	2083	1930	1981	2216		
	RJ	inch	10"	11 5/8"	13 1/8"	14 1/8"	17 1/8"	20 1/8"	22 1/8"	26 1/8"	31 1/8"	33 1/8"	35 1/8"	39 1/8"	43 1/8"	47 1/4"	51 3/8"	55 3/8"	57 1/2"	61 1/2"	65 1/2"	70 5/8"	82 5/8"					
		mm	254	295	333	359	435	524	562	664	791	841	892	994	1095	1200	1305	1407	1461	1562	1664	1794	2099					
	H	inch	19"	19 3/4"	22 3/4"	26"	31"	41 1/2"	42 3/4"	52 1/4"	61 1/4"	71 1/4"	75 1/4"	90 3/4"	94 1/2"	98 5/8"	105 7/8"	113"	126 3/4"	140 1/2"	152 3/4"	164 1/2"	179 1/2"	207 3/4"	214	222		
		mm	483	501	579	660	787	1054	1086	1327	1556	1810	1911	2305	2400	2505	2689	2870	3219	3569	3880	4178	4559	5277	5436	5639		
	W	inch	9"	9"	10"	12"	14"	18"	22"	22"	26"	30"	30"	33"	33"	33"	33"	39 3/8"	Gear operated									
		mm	228	228	254	305	356	457	559	559	660	762	762	838	838	838	1000											
Net weight	RF	lbs.	75	93	159	179	295	463	602	1135	1642	2269	3393	4226	6085	7826	10637	13349	15278	17196	19577	20767	24251	35715	40785	62831		
		kg	34	42	72	81	134	210	273	515	745	1029	1539	1917	2760	3550	4825	6055	6930	7800	8880	9420	11000	16200	18500	28500		
	BW	lbs.	66	82	141	161	260	397	571	939	1422	2092	2551	4072	5082	6944	9731	12520	14616	16501	18684	19676	22895	33532	38404	59557		
		kg	30	37	64	73	118	180	259	426	645	949	1157	1847	2305	3150	4414	5679	6630	7485	8475	8925	10385	15210	17420	27015		

GATE VALVE CLASS 900

Overall dimensions	NPS	inch	1 1/2"	2"	2 1/2"	3"	4"	5"	6"	8"	10"	12"	14"	16"	18"	20"	22"	24"	
	DN	mm	40	50	65	80	100	125	150	200	250	300	350	400	450	500	550	600	
	RF;	inch	12"	14 1/2"	16 1/2"	15"	18"	22"	24"	29"	33"	38"	40 1/2"	44 1/2"	48"	52"	26 1/2"	61"	
	BW	mm	305	368	419	381	457	559	610	737	838	965	1029	1130	1219	1321	1435	1549	
	RJ	inch	12 1/2"	14 5/8"	16 5/8"	15 1/8"	18 1/8"	22 5/8"	24 1/8"	29 1/8"	33 1/8"	38 1/8"	40 7/8"	44 7/8"	48 1/2"	52 1/2"	57 7/8"	61 3/4"	
		mm	317	371	422	384	460	575	613	740	841	968	1038	1140	1232	1334	1470	1568	
	H	inch	26"	26 1/2"	27 3/4"	28 1/2"	32 3/4"	39 5/8"	46 1/2"	51 1/4"	63 1/4"	73 3/4"	81 7/8"	85 3/8"	98 1/2"	103 3/4"	108 7/8"	114 1/4"	
		mm	660	673	705	724	832	1006	1181	1302	1606	1873	2080	2169	2502	2635	2765	2902	
	W	inch	12"	12"	12"	12"	14"	20"	20"	26"	30"	30"	33"	33"	39 3/8"	Gear operated			
		mm	305	305	305	305	358	508	508	660	762	762	838	838	1000				
Net weight	RF	lbs.	79	262	267	366	492	794	1098	1907	2319	3538	4903	6620	8547	10719	13413	16107	
		kg	36	119	121	166	223	360	498	865	1052	1605	2224	3003	3877	4862	6084	7306	
	BW	lbs.	71	212	243	291	410	650	888	1567	1836	2987	4173	5659	7277	8935	11310	13682	
		kg	32	96	110	132	186	295	403	711	833	1355	1893	2567	3301	4053	5130	6206	

5. BASIC TRIM MATERIALS

TRIM Number	Nominal TRIM	Material Type	Seat Surface	Stem	Backseat Bushing
			Hardness [HB]		
1	F6	13 Cr	250 min	200 min - 275 max	250 min
			300 min		
2	304	18 Cr - 8 Ni	Manufacturer's Standard		
5	HF	Co - Cr A	350 min	200 min - 275 max	250 min
		Ni - Cr			
8	F6 / HF	13 Cr	250 min	200 min - 275 max	250 min
		Co - Cr A	350 min		
		13 Cr	250 min		
8A		Ni - Cr	350 min		
10	316	18 Cr - 8 Ni - Mo	Manufacturer's Standard		
12	316 / HF	18 Cr - 8 Ni - Mo	Manufacturer's Standard		
		Co - Cr A	350 min	Manufacturer's Standard	
12A		18 Cr - 8 Ni - Mo	Manufacturer's Standard		
		Ni - Cr	350 min	Manufacturer's Standard	

GATE VALVE CLASS 1500

Overall dimensions	NPS	inch	1 1/2"	2"	2 1/2"	3"	4"	5"	6"	8"	10"	12"	14"	16"	18"	20"	22"	24"
	DN	mm	40	50	65	80	100	125	150	200	250	300	350	400	450	500	550	600
	RF;	inch	12"	14 1/2"	16 1/2"	18 1/2"	21 1/2"	26 1/2"	27 3/4"	32 3/4"	39"	44 1/2"	49 1/2"	54 1/2"	60 1/2"	65 1/2"	71"	76 1/2"
	BW	mm	305	368	419	470	546	673	705	832	991	1130	1257	1384	1537	1664	1803	1943
	RJ	inch	12 1/2"	14 5/8"	16 5/8"	18 5/8"	21 5/8"	27 1/8"	28"	33 1/8"	39 3/8"	45 1/8"	50 1/4"	55 3/8"	61 3/8"	66 3/8"	72"	77 5/8"
		mm	317	371	422	473	549	689	711	841	1000	1146	1276	1407	1559	1686	1829	1972
	H	inch	23 3/4"	24 1/4"	27 7/8"	30 3/4"	35 7/8"	41 1/2"	47 1/4"	56 3/4"	68 1/2"	80 3/4"	86 5/8"	99 3/8"	110 1/4"	123 5/8"	127 3/4"	131 3/4"
		mm	603	616	708	781	911	1054	1200	1441	1740	2051	2200	2524	2800	3140	3245	3346
	W	inch	12"	12"	12"	14"	16"	20"	22"	30"	33"	33"	39 3/8"	Gear operated				
		mm	305	305	305	358	406	508	559	762	838	838	1000					
Net weight	RF	lbs.	194	216	260	437	758	1230	1702	2921	4275	7202	9076	15333	19844	24559	32055	40124
		kg	88	98	118	198	344	558	772	1325	1939	3267	4117	6955	9001	11140	14540	18200
	BW	lbs.	165	187	291	355	536	899	1261	2590	3404	5871	7059	13234	17072	21083	28572	36799
		kg	75	85	132	161	243	408	572	1175	1544	2663	3202	6003	7744	9563	12960	16692



SC ARIO SA
 10 Industriei Street
 4400 - Bistrita, Romania
 phone: +40-263-234160
 fax: +40-263-234008
 e-mail: info@ario.ro
 www.ario.ro